

# Developing a Communication Infrastructure for the Smart Grid

V.K. Sood, *Fellow, IEEE*, D. Fischer, *Senior Member, IEEE*, J.M. Eklund, *Member, IEEE*, T. Brown, *WireIE*

**Abstract**— The Smart Grid of the future, while expected to affect all areas of the Electric Power System, from Generation, to Transmission, to Distribution, cannot function without an extensive data communication system. Smart Grid has the potential to support high levels of Distributed Generation (DG); however the current standards governing the interconnection of DG do not allow the implementation of several applications which may be beneficial to the grid. This paper discusses some of the Smart Grid applications, and estimates the communication requirements of a medium data intensive Smart Grid device. Two issues that will become very important with the spread of DG are DG Islanding and DG Availability. For each issue, we propose data communication enabled solutions and enhancements.

**Index Terms**—Smart Grid, Distributed Generation, Islanding

## I. INTRODUCTION

THE term “Smart Grid” refers to a completely modernized electricity delivery system which monitors, protects and optimizes the operation of its interconnected elements from end to end. The system includes central and distributed generators through the high-voltage network and low-voltage distribution system, to industrial users and residential building automation systems, to energy storage installations and to end-use consumers and their thermostats, electric vehicles, appliances and other household devices [1][2]. Smart Grid will be characterized by a two-way flow of electricity and information to create an automated, widely distributed energy delivery network. It incorporates into the grid the benefits of distributed computing and communications, to deliver real-time information to balance power supply and demand.

Smart Meters are but one element, out of many, that will make up the Smart Grid of the future. Within Canada, Ontario is leading the implementation of the Smart Grid. Already, by the end of 2008, well over 1 million Smart Meters had been installed and will soon be providing the data that utilities (such as Hydro One, Toronto Hydro etc) will use to provide their customers with time-of-use billing.

Today’s electricity grid was designed and constructed to

meet the demands of the 20th century. The grid was primarily radial, built for centralized generation, with few sensors, and dependent on manual restoration. Customers were faced with emergency decisions that were made over the phone link, there was limited price information and few customer choices were offered. The power demands on today’s grid are generally stable and predictable. Any variability in demand is defined by customer behavior, weather or environmental conditions. However, a perfect storm is brewing on the horizon as utilities and their customers are faced with growing demand, an aging infrastructure, an aging workforce, environmental concerns and diminishing fossil fuel supplies. The next generation Smart Grid will be required to accommodate increased customer demands for improved power quality and energy efficiency. Higher fuel costs and regulation in respect of CO<sub>2</sub> emissions and other environmental concerns will also have an impact on how the grid will be operated. Already the integration of utility level wind and solar farms are underway and by 2010 about 2 GW of generation capacity will be available. Many more points of generation such as “run-of-river” hydro-electric, bio-energy as well as residential wind and solar sources, will also become mainstream. It is expected that electric vehicles will increase the demand for more power while at the same time become a significant source of storage capacity. Appliances in the future will incorporate power management features that could take advantage of time-of-use billing schedules. Clearly, the addition of these new elements will result in an increase in the complexity of the power system. Control systems will have to be modified and new operating procedures will need to be developed. This development will have to deal not only with the bidirectional power flows which may occur in what used to be essentially a radial distribution system, it must also accommodate the two-way data communication system required to manage all of these new applications and assets. Such a system would be capable of reporting network state and performance, and will result in increased efficiency by greatly improving the accuracy of energy production and usage forecasting. Two-way communications will enable the accommodation of Distributed Generation (DG) and assist in the re-alignment of the network topology for more efficient power flow. This will require the use of monitors and sensors throughout the network. Self-monitoring will enable the semi-automated restoration (self-healing) of the network. Adaptive protection and islanding will be requirements and will provide new functionalities for the network. All of the network equipment will be monitored remotely enabling decision

---

This work was supported in part by the Canadian Natural Sciences and Engineering Research Council under Grant 1458.

V.K. Sood, D. Fischer and J. M. Eklund are with the Faculty of Engineering and Applied Science, University of Ontario Institute of Technology, Oshawa ON L1H 7K4 (Canada) (e-mail of corresponding author: vijay.sood@uoit.ca).

T. Brown is with Wire-IE, Richmond Hill, ON (Canada).

support systems resulting in predictive reliability which will enhance the mean time before failure rates. The use of pervasive control systems will improve efficiency and stability of the network. The Smart Grid will also offer many customer choices such as full price information enabling them to make intelligent and cost effective choices.

Designing a communication system architecture that meets these complex requirements is key to the successful implementation of the Smart Grid of the future. It must include a secure communications network that will support next generation applications. It must have the bandwidth to retrieve, cull, manage, store and integrate the large amounts of data that smart devices will produce. It must incorporate open standards and permit plug and play integrated approaches that will minimize the risk of implementing stranded technologies. The communication system will have to cover the entire length and breadth of the Smart Grid to cover all aspects of generation, transmission, distribution and user networks. The Smart Grid covers a large geographical territory i.e. extending from remote generation sites to congested urban centers, sparsely populated rural areas, and inside buildings and homes. Communication links will therefore need to use all kinds of resources i.e. varying from hard-wired links to fibre-optics, wireless, satellites and micro-wave links. Considering that there is a lack of standards at present, the communication network will have to evolve with the developing Smart Grid. It will also have to cope concurrently with both legacy and next generation applications.

## II. TYPICAL SMART GRID APPLICATIONS AND COMMUNICATION NEEDS

One of the benefits touted for the Smart Grid containing embedded renewable energy systems is the possibility of forming islands when separation from the main grid occurs due to fault conditions or system/equipment failures. Two potential scenarios within a Smart Grid scenario are considered here to evaluate their communication requirements: a sparsely populated rural environment or a densely populated, highly integrated meshed urban environment.

### A. Rural Radial Distribution System

A rural radial distribution system incurs above-average costs when energy has to be transmitted long distances from the remote generating plant. The need to supply isolated locations increases the costs of the distribution network and, in addition, electrical losses are incurred in feeding the energy to the extremities of the system. In such instances, renewable electricity generating technologies offer benefits to deliver energy closer to consumer demand than centralized generation.

If a radial distribution system suffers a fault at the feeder transformer level, it will result in the opening of the breaker B1 (Figure 1). An interruption due to the opening of the Breaker B1 can create a micro-grid with feed from an embedded wind generator G1. This islanded system can obviously provide benefits of continuity of supply to the consumers at Loads 1 and 2 when the main feeder source of

supply is absent. The loads may or may not have to be scaled back depending upon the rating capacity of the embedded generator G1, availability of wind power, and the reactive power support available within the micro-grid from a Static Var Compensator (SVC) or other such equipment (i.e. power factor correction capacitors). The pre-fault and post-fault scenarios will need investigation to determine any dynamic impact on the islanded system due to separation from and re-connection to the main feeder system. Coupled with analyzing the system behaviors are the necessary sensors and telecommunications links.

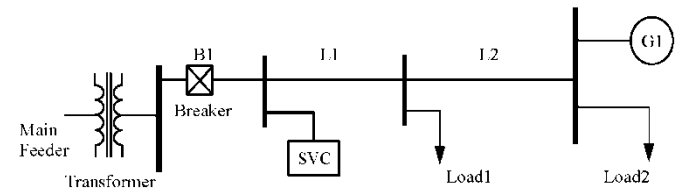

Fig. 1. Rural Radial System

Sensors (not shown) will monitor system conditions, such as (a) detection of the fault at the transformer, (b) condition of the breaker B1, (c) power flow magnitudes and directions in distribution lines L1 and L2, (d) power flow from the wind generator G1, (e) bus voltages and line currents (f) synchronization of the closing of the breaker B1 to re-connect the islanded system to the main feeder once the fault condition is removed.

The telecommunication system will assist in tracking all the data collected by the sensors and permit/enable the Supervisory Control System to perform its functions with/without Operator intervention.

The operational aspects of system reliability and safety of personnel who may need to be actively engaged must be considered as well.

### B. Urban Meshed Distribution System

This urban system has feeds from two different points within a larger grid system (Figure 2). Interruption of supply does not occur to the loads of the sub-system if either breaker B1 or B2 are opened. However, re-connection of either of these two feeds can create potential synchronization problems. Theoretically, the formation of an islanded sub-system within the meshed distribution network is feasible, but sensing and operational difficulties present themselves. Under such circumstances, the protection of equipment and security and safety of personnel can play a major role in the supervisory and control methods to be employed.

These two illustrative example cases will be subjects of closer study in later, as yet undefined, phases of the project.

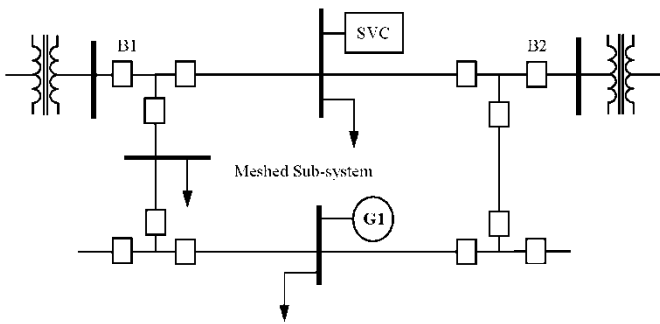

Fig.2. Urban Meshed System

### C. Data Requirements

Some of the typical data requirements for these two systems are provided in Table 1. Sensors will be placed at appropriate sites within the system, and the data gathered will then be communicated either locally or to a centralized location for appropriate action(s).

TABLE I  
SAMPLE DATA REQUIREMENTS

System Component	Inputs	Outputs	Computed Values
Breakers Switches Protective elements (Fuses)	Breaker Status Enable/Disable	Breaker Status Voltages Currents	
Generators: Wind Solar (PV)	Enable Dispatch (?)	Voltages Currents Phase (?)	Power Quality Availability Health index Power
Transformers	Tap Positions	Temperature Pressure Gas, Vibration Noise	Reliability
Lines	Enable/Disable	Voltages Currents	Real Power Reactive Power
Reactive Power Elements	Status Enable/Disable	Voltages Currents	Power Quality
Loads: Active Passive	Status Enable/Disable Rate (Tier Demand Management) Demand	Voltages Currents	Power Quality

### III. ESTIMATED COMMUNICATION THROUGHPUT

It is expected that a typical Smart Grid device will have access to measured line voltages and currents. Assuming such quantities to be sampled 16 times per 60 Hz cycle, 960 samples will be produced per second for each measured quantity, approximately 1Ksample/s/quantity. Assuming the analog to digital conversion uses a 16 bit word, the acquisition results in a 2 Kb/s/quantity throughput. Such a sampling rate results in a built-in delay of 1 ms for any process in need of the sampled data. Assuming 3 voltages and 3 currents are to

be sampled, a basic 12 Kb/s is required to broadcast the raw data samples. It is expected that beside raw data, computed quantities (i.e. phase amplitude, phase angle, sequence components, etc.) will increase the bandwidth requirement to around 200–500 Kb/s, or to 2-5 Mbits/s. Of course, these data rates must be supported by a communication protocol which will make use of additional information such as node addresses, data error detection/correction, packet and message routing, etc., resulting in an increased required bit rate. The 2-5 Mbits/s data rate should be considered indicative of an application with a relatively low to medium data rate production and may be used as a guideline.

### IV. ISLANDING ISSUES

#### A. DG Islanding

According to IEEE Std. 1547-2003, islanding is defined as a condition in which a portion of an Area Electric Power System (EPS) is energized solely by one or more local EPSs through the associated PCCs while that portion of the Area EPS is electrically separated from the rest of the Area EPS. The standard specifies that for an unintentional island in which the Distributed Resource (DR) energizes a portion of the Area EPS through the point of common coupling (PCC), the DR interconnection system shall detect the island and cease to energize the Area EPS within 2s of the formation of an island. While IEEE Std. 1547-2003 states that intentional islanding is a topic under consideration for future revisions of the standard, utilities such as Hydro One state that intentional islanding is not allowed at this time [3]. Some of the reasons stated by Hydro One why islanding is not allowed are:

1. To ensure that Hydro One customers do not experience power quality problems such as abnormal voltage and frequency excursions outside of the acceptable ranges
2. To prevent out-of-phase reclosing between the distribution system and the DG facility and interference with the restoration of normal supply from the utility
3. To reduce the risks of safety hazards to public and utility workers caused by islanding since lines may be energized when it is assumed they are disconnected from all energy sources
4. To add redundancy to other protections meant to clear faults that cannot be detected by the DG self-clearing protections within required time
5. To prevent the utility from being liable under conditions it does not have control over

While islanding is not allowed by utilities, one of the frequently quoted positive features of the future Smart Grid is the ability of DG to continue to supply power to loads, while the grid is down, and also to assist in the grid restoration process [4][6][7][8][9][10][11]. Clearly, these conflicting approaches will have to be reconciled, and a likely solution will be the use of the bidirectional communication system of the Smart Grid to control and monitor the status of DGs. Since this communication requirement will impose very little throughput overhead, it can be used for all DGs, regardless of

their size. The possibility to use the data communication system to monitor and control even small DGs will dispense with the need to accept increased-risk passive anti-islanding protections, as an interim solution for DG interconnection of 500 kW and less, as an interim solution [3]. The fact that passive anti-islanding systems are indeed high risk solutions is apparent from their testing. Reference [5] presents results of testing of the passive anti-islanding algorithm used by a specific manufacturer. It is shown that one such unit shuts off within 0.7 sec, well below the 2 sec required by IEEE Std. 1547-2003. The reference also shows that, if four such units were to be connected in parallel, the anti-islanding algorithm will shut the systems down within 1.9 sec, thus meeting the standard requirement. Of course, if one considers the fact that the shut down time has dramatically increased, when the number of DG units working in parallel has been increased, the obvious issues to be investigated are the effect of a larger than four number of DG units connected in parallel, on the shut off time, and also, the effect of using DG units from different manufacturers (which may use different passive anti-islanding algorithms), on the shut off time. Clearly, the passive algorithm approach poses risks, while a communication based transfer trip implementation is a safe solution.

### B. DG Availability

The issue of DG availability and its impact on the utility can be settled in contractual agreements. Such an arrangement is appropriate for relatively large DG units. However, in the case of very small PV DG systems, diagnostic and monitoring systems coupled with communication support, will be essential, if an aggregate of such units is to be effectively managed. Each unit will have to be monitored not only for delivered active power, but also for behavior indicative of reduced performance. A PV may deliver a low level of power either because of atmospheric conditions, or because of internal conditions such as aging or poor maintenance. Diagnostic system will run either in each DG, or in a computer system that monitors many DGs in geographical proximity, thus mitigating atmospheric effects. The Smart Grid's ability to collect or share data from many DGs allows the usage of failure detections algorithms that automatically build empirical models of systems that function at correct levels, and have no need for theoretical models that would likely be manufacturer and model dependent. Such an approach will exploit the high level of behavior correlation of DGs in the same geographical area, and be able to not only detect which DGs do not perform at the expected level, but also estimate the level of performance degradation.

### C. DG Control within the Smart Grid

From a control perspective, the Smart Grid can be described as a hierarchical, heterogeneous supervisory control system. This is a way of characterizing the different levels of supervisory control within the primarily distributed control architecture of the current grid and the Smart Grid.

From this perspective, decisions on islanding of a DG as well as several of the other DOE Smart Grid objectives listed

at the start of this section will require some level of centralized (at least locally or regionally) supervisory control with incorporated information from source outside the boundaries of the supervisory control systems area of control.

Following the Radial System example this external information would come from the other side of the breakers, and might include information about nearby DG systems' current stability.

The data acquired and used for such a system will be of varying data rates, data types and also availability.

As one example of such data, it is expected that the data throughput, via the Smart Grid communication system, required by such a fault detection system, is minor, of the order of tens of kB/sec, for each DG. The maximum data latency (i.e. the delay between when information is sent to when it is available at the other end of the communication system, and that this can include the round-trip latency in which the processing time, for instance for a controller, and return latency are taken into consideration), for this application, is extremely relaxed, of the order of minutes.

On the other end of the rate spectrum, system faults require continuous, high rate monitoring on the order of millisecond sampling resulting in throughputs of up to 5 Mb/sec and latencies in the tens of ms to allow for rapid detection of faults, with 5-6 cycles (80-100 ms) being the accepted fault detection times.

As for heterogeneous data types, it is possible to envision a Smart Grid supervisory control system that should incorporate other types of data including weather conditions, scheduled maintenance and other types of incidents that could affect supply, demand or both.

New methods for using these data in supervisory controller will be needed, and one area where tools are emerging is that of real-time stream event processing.

## V. DATA MANAGEMENT

### A. Data Management: Leveraging Decades of Development in Operation Support Systems

An IP-based Smart Grid network has the added benefit of standardized integration with data aggregation and analysis environments.

Today's cellular networks share a common operational characteristic with the way Smart Grid is envisioned. While important assets are at the network core, there are also critical interdependent assets found at the network's edge. In the wireless world, cellular base stations are at the edge of the fixed network but beyond that are the operator's customers with their mobile handsets and smart phones. Over and above service delivery to these devices, countless administrative functions are carried out between Operations Support Systems (OSS) in the network core and these devices in the hands of the network operator's subscribers.

Smart Grid is envisioned as having key assets in a decentralized topology – the possible exception being the data analysis function which, like the cellular world, is likely to be centralized.

Operation Support Systems found in today's advanced telecommunications networks are ideal candidates from which

to evolve a Smart Grid data management environment. The services available in an Operation Support System are layered in a pyramid fashion (Figure 3). At the foundation is the Business Management level. Based on the rules set out in the Business Management level, a Service Management level is defined. A Network Management level follows with an Element Management level completing the suite. This hierarchy ensures that fundamental business principles of the utility translate directly into an operational reality within the grid itself. Many Operation Support Systems are based on the International Telecommunications Union (ITU) FCAPS model representing: Fault, Configuration, Accounting/Administration, Performance and Security.

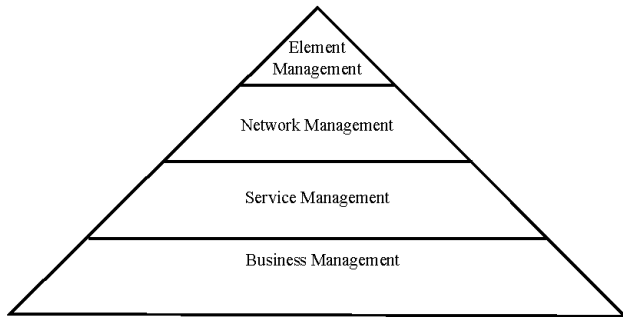

Fig.3. Operation Support System

Operation Support Systems are a mature, proven, integral component found in any telecommunications network. These systems often reach out to tens of thousands of network elements and return data on countless operational and performance parameters on a per element basis.

### B. Architecture

In the context of DG, the communications network shall support:

- All protection and control transition points including facilities on the grid itself, in addition to businesses and residences where alternative energy is available to the grid.
- Connectivity to a data aggregation and warehousing environment.
- A Network Operation Centre

### C. Latency

Common to both the rural islanding and urban meshed distribution scenarios is the potential need for a communications infrastructure with exceptionally tight latency characteristics. The extreme time-sensitivity of these factors results in a tolerance for a maximum latency of 6 cycles, or 100 ms. The communications network supporting these scenarios must therefore strictly respect this latency constraint.

It is conceivable the grid operator has access to fiber optic facilities, either owned directly or leased. Latency is exceptionally low with fiber optic – the rule of thumb being just under 5  $\mu$ s latency per kilometer length of strand.

Where fiber is not available to the system operator, or where fiber is available to some, but not all points in the system, the use of wireless technology is very attractive. One wireless network technology exhibiting very good latency

characteristics is WiMAX (Worldwide Interoperability for Microwave Access).

Latency in a WiMAX link from base station to CPE (customer premises equipment) is typically equal to or less than 10 ms. The core infrastructure, responsible for linking elements in the WiMAX network, must therefore be engineered such that aggregate latency is kept safely below 50 ms on all paths.

Based on IEEE Stds. 802.16d (fixed), and 802.16e (mobile data), the WiMAX suite of standards offer a number of sophisticated capabilities over and above impressive latency characteristics.

A typical WiMAX network in a Smart Grid would see a channel bandwidth no larger than 5 MHz with a corresponding throughput of between 1 and 4 Mbps per link. This substantial network capacity, married with attractive latency characteristics, positions WiMAX well for power and control applications in Smart Grid.

The WiMAX standard employs dynamic radio link quality management capabilities. Throughput is traded off for link robustness in the event the quality of a WiMAX radio path should deteriorate. The reverse is also true as radio path quality improves. The mechanism facilitating throughput verses robustness is known as adaptive modulation. A companion mechanism to adaptive modulation is WiMAX's closed loop power control. In addition to assisting in the control of network self-interference, closed loop power control has the added benefit of minimizing electrical power consumption of the WiMAX radio equipment. The adaptive modulation and closed loop power control features in WiMAX are sufficiently sophisticated that each radio link served by a given WiMAX base station will have its own modulation and power control settings.

While adaptive modulation and closed loop power control are impressive features in WiMAX, it is essential that each radio link be engineered to exceptionally strict path propagation specifications because of the mission-criticality of Smart Grid protection and control applications. This entails exhaustive path analysis and a subsequent network design that ensures a radio path is never at risk of engaging a modulation scheme below a carefully calculated threshold. As a fixed (non-mobile) network, radio link reliability can be achieved with a high degree of predictability. In addition, network redundancy and/or diversity can be incorporated into the design, thus enhancing overall reliability and equally important, allowing for network fail-over scenarios.

It is recognized that a WiMAX Smart Grid network will be used for applications over and above protection and control automation and management. Inherent in the WiMAX standard is what is known as Quality of Service, more commonly termed QoS. This powerful feature will allow a Smart Grid operator to prioritize traffic on the WiMAX network. It is anticipated that protection and control functions will be given preferential status and that other Smart Grid applications will fall below in priority order as appropriate.

Wireless telecommunications network operators in the western hemisphere, and indeed much of the world, are contemplating the next generation of network technology know as Long Term Evolution, or LTE. As with WiMAX, LTE is a fourth generation wireless networking technology

with a broad roll-out targeted in the year 2012 timeframe. Sharing many of its radio characteristics with WiMAX, LTE boasts latency figures of 5 to 10 ms. Should these figures be realized in production networks, it is conceivable that a Smart Grid system operator could contemplate using LTE in addition to, or instead of, WiMAX should capital or operational costs make such a selection attractive.

#### *D. The Internet Protocol: Flexibility, Simplicity and Cost Effectiveness Derived from Standardization*

In the world of modern internet working, the Internet Protocol (IP) is a pervasive and credible ingredient. Both WiMAX and LTE are built on IP.

It is the standardization based on IP that has led to the global adoption of the Internet in business, industry, government, education, healthcare and society at large. The limitless evolution of Internet and World Wide Web applications is directly facilitated by the openness inherent in IP. Smart Grid is ideally positioned to benefit from the adoption of IP as the protocol by which the human race communicates.

By adopting an all-IP philosophy, Smart Grid benefits by having an open, secure network with the greatest degree of design flexibility, including redundancy and diversity, while also retaining relative simplicity. Deployment and operational costs are also reduced as many key network components are now commoditized items.

The standardization inherent in IP allows for virtually effortless interconnection with neighboring networks (including those of other operators).

Strictly speaking, IP in of itself is not a direct factor in network latency. Rather, latency is a direct function of the transmission media used (e.g. fiber optic cable, copper wire, radio signal etc.). There are, however, characteristics of the transport mechanisms supported by IP that can introduce payload latency.

Protocol related delays can occur when the Transmission Control Protocol (TCP) is used on an IP network. TCP offers the highest level of packet delivery assurance, but this comes at a price. By its very nature, TCP introduces the burden of comparatively high network overhead because of its mechanism for responding to corrupted and collided packets. The degree to which resultant retransmissions impact payload latency is largely determined by the quality of the transmission media, along with loading on the communication channel.

The User Datagram Protocol (UDP) is lightweight in contrast to TCP's overhead but it comes at the cost of non-assured packet delivery as there is no acknowledgement of receipt mechanism. UDP has become a common mechanism for Internet delivered multimedia content where packet loss is imperceptible under normal conditions. Applications for UDP are typically written to factor in the likelihood that some packets will be lost or corrupted over the course of the session.

When considering the mission criticality of Smart Grid protection and control applications, three attributes are required: low latency, prioritization through QOS, and TCP. Conversely, UDP is suitable for Smart Grid applications where a packet receipt acknowledgement mechanism is not required.

## VI. POTENTIAL ISSUES

### *A. Regulatory issues*

IEEE Std. 1547-2003 governs the interconnecting of Distributed Resources (DR) with Electric Power Systems. The criteria and requirements specified in the standard are applicable to all DR technologies, with aggregate capacity of 10 MVA or less at the point of common coupling, interconnected to electric power systems at typical primary and/or secondary distribution voltages. This standard focuses on the technical specifications for, and testing of, the interconnection itself, and not on the types of the DR technologies. It provides requirements relevant to the performance, operation, testing, safety considerations, and maintenance of the interconnection. It includes general requirements, response to abnormal conditions, power quality, islanding, and test specifications and requirements for design, production, installation evaluation, commissioning, and periodic tests. The stated requirements are universally needed for interconnection of DR, including synchronous machines, induction machines, or power inverters/converters and will be sufficient for most installations. Installation of DR on radial primary and secondary distribution systems is the main emphasis of this document. According to the standard, each DR unit of 250 kVA or more or DR aggregate of 250 kVA or more at a single point of common coupling (PCC) shall have provisions for monitoring its connection status, real power output, reactive power output, and voltage at the point of DR connection. The corollary of this requirement is that smaller distributed resources do not have to have monitoring and control provisions.

IEEE Std. 929-2000 is the IEEE recommended practice for utility interface of photovoltaic (PV) systems. This recommended practice applies to utility-interconnected PV power systems operating in parallel with the utility and utilizing static (solid-state) inverters for the conversion of dc to ac. This recommended practice describes specific recommendations for small systems, rated at 10 kW or less, that may be utilized on individual residences. Intermediate applications, ranging from 10 kW to 500 kW, follow the same general guidelines as the small systems. However, options to have adjustable set points or other custom features may be required by the inter-connecting utility, depending on the impact of the PV system on the portion of the utility system to which it is interconnected. Large systems, greater than 500 kW, may combine various standardized features as well as custom requirements, depending on the impact of the PV system on the portion of the utility system to which it is interconnected.

It is clear that, since IEEE Std. 929-2000 does not require small PV DGs to have any monitoring and control facilities, a Smart Grid which treats such DGs as individual power produces, will have to address this issue.

## VII. CONCLUDING REMARKS

The Smart Grid of the future, while expected to affect all areas of the Electric Power System, from Generation, to Transmission, to Distribution, cannot function without an extensive data communication system. Smart Grid has the

potential to support high levels of DG; however, the current standards governing the interconnection of DG will have to be amended. Moreover, with the support of data communication and distributed processing, DGs, regardless of size, can be monitored, controlled, and assessed, in a truly intelligent way.

### VIII. ACKNOWLEDGMENT

The authors acknowledge the contributions of R. Barlow of Wire-IE International Inc. and R. Marceau of UOIT for their support of this work.

### IX. REFERENCES

- [1] Report to NIST on the Smart Grid Interoperability Standards Roadmap. (EPRI), Electric Power Research Institute. June 17, 2009, Vols. Contract No. SB1341-09-CN-0031.
- [2] Smart Grid Activities at the Department of Energy. DOE, US. May 7, 2008, Vols. Presented to FERC-NARUC Collaborative Leadership.
- [3] Hydro One Networks Inc., Distributed Generation Technical Interconnection Requirements. Interconnections at Voltages 50kV and Below. February, 2009. Rev. 0.
- [4] Thi Thu Ha Pham, Yvon Bésanger, Nouredine Hadjsaid., “New Challenges in Power System Restoration with Large Scale of Dispersed Generation Insertion.” IEEE Trans. on Power Systems, February, 2009, Vol. 24.
- [5] Raymond M. Hudson, Tony Thome. Fereydoun Mekanil, Michael R. Behnke, Sigifredo Gonzalez, “Implementation and testing of anti-islanding algorithms for IEEE 929 – 2000. Compliance of Single Phase Photo Voltaic Inverters 0-7803-747 1-1, 2002.
- [6] A. D. T. Le, M. A. Kashem, M. Negnevitsky, and G. Ledwich, “Control strategy of distributed generation for voltage support in distribution systems,” Proc. Int. Conf. Power Electronics, Drives and Energy Systems, pp. 1–6, Dec. 12–15, 2006.
- [7] D. A. M. Geldtmeijer, F. Provoost, J. M. A. Myrzik, and W. L. Kling, “Transient short-circuit behaviour of distributed energy sources and their influence on protection coordination,” Proc. 41st Int. Universities Power Engineering Conf, UPEC’06, vol. 2, pp. 536–539, Sep. 6–8, 2006
- [8] Y. Hayashi and J. Matsuki, “Loss minimum configuration of distribution system considering N-1 security of dispersed generators,” IEEE Trans. Power Syst., vol. 19, no. 1, pp. 636–642, Feb. 2004.
- [9] J. H. Choi, J. C. Kim, and S. Moon, “Integration operation of dispersed generations to automated distribution networks for network reconfiguration,” in Proc. IEEE Power Tech Conf., Bologna, Italy, Jun. 23–26, 2003, vol. 2, pp. 5–5.
- [10] B. Enacheanu, M. Fontela, C. Andrieu, T. T. H. Pham, and A. Martin, “New control strategies to prevent black-out: Intentional islanding operation in distribution networks,” in Proc. CIRED 18th Int. Conf. Electricity Distribution, Turin, Italy, Jun. 6–9, 2005.
- [11] T. T. H. Pham et al., “A new restoration process in power system with large scale of dispersed generation,” Proc. 2005/2006 IEEE PES Transmission and Distribution Conf. Expo., Dallas, TX, May 22–24, 2006.

### X. BIOGRAPHIES

**Vijay K. Sood** obtained a Ph.D. degree from University of Bradford, England in 1977. From 1976-2007, he was a Researcher at IREQ (Hydro-Québec) in Montreal. In 2007, he joined the University of Ontario Institute of Technology, Oshawa as an Associate Professor. He is also an Adjunct Professor at Concordia University, Montreal. He is a Fellow of the Engineering Institute of Canada (1999) and Fellow of IEEE (2006). He is an editor of the IEEE Transactions on Power Delivery. He is the author of two textbooks on HVDC Transmission.

**Daniel Fischer** obtained a Ph.D. degree from McMaster University in 2003. From 1988-2008, he was a Senior Research Engineer at Kinectrics (former Ontario Hydro Research Division) in Toronto where he has developed a number of Artificial Intelligence based Fault Detection Systems used in electric power applications. In 2008, he joined the University of Ontario Institute of Technology as a Lecturer.

**Mikael Eklund** obtained a Ph.D. degree from Queen’s University in Kingston in 2003. From 1989 to 1996 he was a Flight Control Systems Simulation Engineer at CAE Electronics Inc., and from 2003 to 2006 he was a Visiting Postdoctoral Fellow in the Department of Electrical Engineering and Computer Sciences at the University of California, Berkeley. He is currently an Assistant Professor and Program Director for Electrical and Software Engineering at the University of Ontario Institute of Technology.

**Tim Brown** is a communications professional with an extensive background in managing technically oriented teams – primarily in the introduction of new technologies. He has worked for market leaders such as Rogers, Telus, Microcell and Visa. Brown is highly accomplished in the introduction of innovative technology solutions that meet strategic business goals. He has experience with various wireless technologies including but not limited to AMPS, GSM, CDMA 1xRTT, iDEN, along with various iterations of 802.11 (Wi-Fi) and 802.16 (WiMAX). He also has a background with web-based technologies including XHTML, CSS, PHP, XML and Flash. This is further augmented by a strong working knowledge of TCP/IP. He is responsible for providing guidance in relation to broadband wireless access and core network technologies. He also promotes, educates and supports clients in realizing the opportunities Wire-IE provides.